

# VELOCITY VIEWS

Volume 38

## Defining Deception

by Kevin Steiner of Scottsdale Arizona



Kevin and Brooke Steiner and their dog Malki pose proudly at twilight with their magnificent Velocity, christened "Deception". Its amazing paint job, extending from the exterior through the interior, disguises this plane as a cloaked alien ship.

**L**OOKING BACK, we often recognize defining moments that set us on particular paths, courses that change our lives forever. One of mine happened in the summer of 1999, while I was doing some aerotowing hang gliding out at Lake Pleasant Airport in Carefree, Arizona. Waiting for the ultra-light that would offer my next tow to altitude, I spied a copy of *Kitplanes* magazine. Having never opened one before, my curiosity was piqued. A few pages in, I found an ad for a Velocity, which I first took to be an RC model, since I had only seen something that cool flying in episodes of *Star Trek*. Reading on, I

could barely believe it was actually a fast, stall-resistant, 4-place general aviation aircraft.

I have always been an "air-junkie". Having earned my private pilot license in 1989, I had dreamed of owning my own plane, namely the Trinidad with its gull wing doors and futuristic instrument panel. Of course, the price tag was considerably out of reach, so relegated to rentals, the thought of ownership had drifted to the back of my mind, where it remained -- that is, until I saw the Velocity.

The timing couldn't have been

*Continued on the next page*

## In this issue

- Defining Deception .....1**  
*The Steiner's Velocity SE FG is a real head turner!*
  
- Builder Hints & Info .....6**  
*Tips from Scott Swing*
  
- Factory News .....8**  
*Total Electrical Failure and more from Duane Swing*
  
- Safety Corner .....12**  
*Accident & Incident Reports and Maintenance Service Difficulties*
  
- CFI Notams .....13**  
*Preflight of Your Velocity*
  
- Production News .....14**  
*Low-tech, high-tech blues*
  
- Maintenance Notes .....15**  
*Inspection & Repair*
  
- Builder Forum .....16**  
*Tips, information & letters*
  
- A&P Talk .....18**  
*Fuel System Alternatives*
  
- Buy Sell or Trade .....19**

## Defining Deception

*Continued from previous page*

better. My wife, Brooke, was in the process of getting her own private pilots license, which she managed to do in a mere 42 hours. And, while I had taken up hang gliding only one year before, Brooke was already urging me to quit. Although riding thermals for hours on end, thousands of feet AGL with nothing between you and the ground is definitely a unique thrill, we had seen a fair share of mishaps, some deadly. Hang gliding has come a long way since the 1970's, but remains very unforgiving of mistakes. Staring at that Velocity in glossy color, I felt the winds of change blow through me, and two months later, I left the sport of hang gliding with memories that will last a lifetime.

After extensive research, Brooke and I agreed to build a Velocity together. In December 1999 we ordered our Elite LWFG (long wing fixed gear) kit with the fast build fuselage and wings. It was delivered to our 2-car garage in Scottsdale, Arizona on February 26, 2000.

### **In the beginning...**

**there was nothing** (but parts)...

As most of you know, to begin building you must first take things apart. We put the top half of the fuselage in our living room on sawhorses (yes, Brooke was fine with it - it may have even been her idea!) and the bottom half was leveled in its cradle in the garage. We worked about 15 hours per week and slowly, very slowly, things got done. Fellow builders imparted their knowledge, and I came to live by the simple mantra, "Do something every day, no matter how small, and we will finish this airplane".

### **Modifications**

It only takes a stint of working with glass and epoxy to become a "fiberglassing god". I can build anything, you say to yourself and set off to customize your plane. Here are our mods:



*Fellow pilots, Kevin and Brooke did extensive research before deciding to build a Velocity together in their Scottsdale, Arizona, garage.*



**Instrument Panel:** The panel was redesigned so that the rocker switches are angled up toward the pilot. Since Brooke and I are both pilots, we wanted to install dual throttle quadrants. I liked the P-51-type throttle lever better than the push-pull knob, so we sculpted foam and

glassed up custom mounting blocks (see photos below) for Beechurst throttle quadrants. I also installed a torque tube that slaves one quadrant to the other. Remember, changing one thing affects ten others... I had to make sure that the torque tube had proper clearance behind the



## Defining Deception

*Continued from previous page*

instrument panel. Aerotronics completed the panel, and did an awesome job. When we hooked it up, everything worked perfectly!

**Keel Covers:** While I was on this custom-glassing frenzy, I decided that I didn't like the carpet-over-the-center-keel look. Why not make fiberglass keel covers that could be painted? Furthermore, why not make a workable glove box under the pilot armrest pad? Of course, the big question I should have been asking was, why not add three months to the building process? Truthfully, it was worth the effort, and if I had to do it all again, I would. These are the kinds of changes that make a plane unique.

**Retractable Tie Downs:** I saw these on another Velocity and tried to improve them a bit. I added nylon washers under the wide area washers that hold them to the ends of the center spar. I also put a stop bolt for the tie down to lock against in the open position. The real trick was designing a retractable tie down for the nose since we have fixed gear without big gear doors. I fabricated



*Says Kevin: "My wonderful and incredibly understanding wife has been involved with the project from its inception. For 3 1/2 years, we cut, trimmed, glassed, sanded - and itched -- together."*



and glassed in two aluminum L-brackets. The tie down is similar to the wing tie downs and is sandwiched between two nylon plates inside the two L-brackets. I also put a stop bolt in the unit.

**Ram Air Scoop:** There are a few reasons we decided to make a ram air scoop to feed air to the throttle body. We live in Arizona, and didn't want to rob any of the engine's cooling air coming in from the top NACA scoops. Also, by bringing the air through the wing root, it offered us a good place to put in an air filter. Made from foam and fiberglass, our ram air scoop is glassed to the underside of the co-pilot wing. A fiberglass wing root cover holds the air filter in place and has a spring loaded alternate air door. A fiberglass tube-like bracket was made to attach the SCEET tube from the air filter cover to the throttle body. Was all of this really necessary? I guess we'll never know. Without the aid of the NASA

computers, we try things one way, based on best guess, and hope we made the right choice. One thing I do know... adding an air filter can't hurt (see photos above).

**Vanity Bulkhead:** Our rear vanity bulkhead has a built-in hinged lid toolbox in the lower shelf. There are some things that must be carried, which are better placed out of view (i.e., oil, funnel, tools, towels, cleaner, etc.).

**Special Lights:** All the rockers and instruments in our panel are backlit. We have the standard Velocity reading lights in the upper air duct and we have custom made green LED map lights mounted above, which attach with flexible antenna-like tubes. In addition, we made brackets to hold 3 LED lights to illuminate each fuel sight-gauge, even though we have the Vision Microsystems

*Continued on the next page*

## Defining Deception

*Continued from previous page*



panel mounted fuel gauges. After all, nothing tells the truth better than actual sight gauges.

### Brackets and Covers

Here's a list of other parts that were custom made:

- \* Fiberglass brackets to hold the fuel filter and boost pump to the firewall
- \* Aluminum tear-shaped main wing bolt hole covers
- \* T-handle locking device for nose access door



- \* Fiberglass relay board
- \* Aluminum auto pilot servo brackets
- \* Aluminum covers for door micro-switches

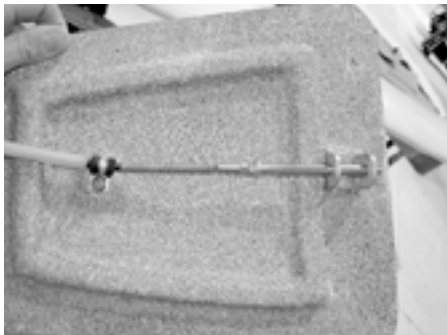

- \* An aluminum landing light bracket to eliminate the springs that usually hold in the landing light.
- \* Spring loaded wheel pant access doors

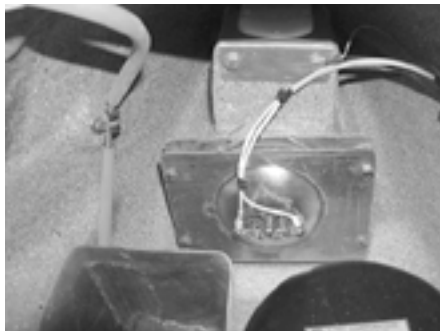

\* Custom designed plenum that is easily removable for maintenance (see photo at bottom).

\* Fiberglass exhaust covers that come off first, offering a larger area for the exhaust pipes to travel in when the lower cowl comes off (see photo above right).



Overall, we're very pleased with our changes, but it is important to note that nothing comes without a price. Every modification adds time. I think



it's essential to pick your battles -- balancing time and cost against actual benefit.

### Along the way...

When you start building you don't even know what you don't know. You're asked over and over again, "When will it be done?"

Each time you give an estimate and feel somewhat sure about it, the date inevitably comes and goes. It's not that you're a liar; it's just that your understanding of what's required is as incomplete as the plane. I didn't know I had to do this. I didn't know I had to do that! Finding a sense of accomplishment in the completion of each tiny step is the key to enjoying the process.

### First flight

Our plane's first flight took place on

*Continued on the next page*



## Defining Deception

*Continued from previous page*

June 13, 2003, when Matt Winberg, a west coast CFI for Velocity, took her for a fast taxi and ended up flying her along the runway. A few weeks later, our good friends Mike Pollock (N173DT Velocity co-owner, Velocity Inspector and Test Pilot), Milt Mersky (N173DT Velocity co-owner) and Dave Bertram (Velocity builder) flew in from Texas for Mike to fully test fly our baby. Aside from the high oil temps expected from a new engine, we had only two minor adjustments to make. We needed to kick out the co-pilot rudder a bit to center the ball, and shim our co-pilot wing to drop the aileron for level flight. Everything else worked great.

### Support team

In my opinion, the two most important things to have in your toolbox are family and good friends. My wonderful and incredibly understanding wife has been involved with the project from its inception. For 3 1/2 years, we cut, trimmed, glassed, sanded -- and itched -- together.

Others helped transport the plane from garage to hangar, flip it over, put the wings on and take them off numerous times, bring things back and forth to the paint shop, etc. Bob Dameron's exceptional electrical and computer knowledge along with his willingness to spend countless hours at the hangar was an incredible gift!

And, of course, the factory's support was outstanding. I'm sure for most of us, the company's reputation was part of the reason we chose Velocity.

### Paint

After moving out of our garage, we shared a hangar with Mike Campbell and his award winning Giles 202, Primal Fear. Even though airbrush artist, Larry Vela, who spends most of his time painting race cars and motorcycles, swore Primal Fear was his last plane, we convinced him to transform one more. His penchant for sci-fi was a perfect match for the project. Our concept was to make the Velocity look like an alien ship,

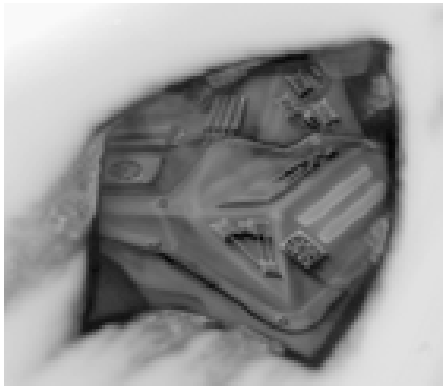

cloaked in white to conceal its extraterrestrial identity. Small sections appear to have sustained damage, burnt away during atmospheric re-entry, exposing the spacecraft underneath. The clean, beautiful shine of the white pearl sharply contrasts the dark, ominous nature of the alien mechanics.

Our plenum is painted to resemble an un-Earthly engine -- circuits, tubes, fans and microprocessors appear 3-D and yellow-orange glows from a vent at the "power source". A painted tear on the upper cowl offers a duplicate view of what lies beneath.

In the cabin, Larry's artwork continues along the rear and forward beams, keel covers and upper air duct. And to complete the concept, we named her "Deception".



### Interior

We chose to have our interior professionally done and hired Linda Burke of Cutter Aviation, who previously owned her own interior shop and did award-winning work for many of Phoenix Composite's Glasairs. We have custom-dyed wine-colored leather seats with smoke colored leather side panels.

### Looking forward...

Now that the plane is finished, people often ask if we're concerned about flying in something we made ourselves -- something that started in our garage. Usually we tell them, "If you'd ever flown in a rental, you wouldn't be asking."

The value of knowing every nut, bolt, tube and wire on the plane you pilot cannot be underestimated. When the DAR is inspecting your plane for its Airworthiness Certificate, there won't be a single question you can't answer or system you won't know inside and out. Having such knowledge offers a tremendous measure of safety.

As for defining moments, I'm sure there will be many ahead as we traverse the country and take in the sights. Brooke and I are excited to experience the freedom and joy of travel in our Velocity. And we hope to see many of you along the way.



# Builder Hints & Information

by Scott Swing

## My Story

Since I do not have the hours that my father has, my story will be rather short. I started flying fairly young with my dad. I remember him saying "it's all yours" as we accelerated on the take off roll. That was scary for a very young boy, but it stuck with me. Eventually, while I was in college in Anderson, Indiana, I started training for my pilots license. I decided not long into the training that I would finish my training back at a small airport near Dayton OH, since I could do it on weekends and summer break and still rent a plane in Anderson to gain time. I soloed at 6 hours and took my check ride at exactly 40 hours, which was the requirement back in 1980. I graduated from college in 1981 and decided to get my masters degree from Wright State University in Dayton. During the summer of 1981, my father and I went to Oshkosh and decided to build a Quickie 2 (or Q2). We received the kit in the fall and 8 months later, while I was going to school, we finished our Q2. Since I was a low time pilot, my father was to do the test flights on the plane. The first flight was done with some ballast in the plane to put the CG back in the middle of the envelope. That flight went well. The next flight was done with the CG at the forward end, and when the plane taxied in after the flight the prop was damaged. When my father got out of the plane, he said it was the hardest plane to land of any of the planes he had flown... and he had flown a lot. In any case, modifications were done to the plane and, in the mean time, I got checked out in a Citabria (tail dragger) so I would be ready for the transition. There would be rides in the Q2 but no dual since it was not

set up for that. I finally got to fly our Q2 in June of 1982. After I graduated from grad school, I took my longest cross-country in the Q2, which was out to California to interview with Gene Sheehan at Quickie Aircraft Co. for a job. They offered me a job and I took it. Working in Mojave was quite an experience as it was during the time of the Voyager and the prototype Starship. Anyway, that job allowed me to travel and fly quite a bit in the Q2. I also test flew many Q2s and some other homebuilts. On the trip back after the interview in California, I was following a tropical storm across the country. I stopped in Albuquerque to see the AOPA convention and to wait on the weather to move east. My college roommate lived in Oklahoma City so I stopped there to wait on the weather but I really wanted to get home. I called weather and it didn't look that good, but like all young bold pilots, I figured I would see what it was like and turn around if I needed to. I had already learned that you can't always believe the forecast. So I took off from Oklahoma City heading for Dayton, Ohio. At Tulsa, I started to get into cloud cover so I descended to get under it. I followed the highway till I got to southern Indiana and at this point the weather was not that great but was still VFR. I called weather again and decided to try to go further. As I got closer to Indianapolis, the weather had really turned for the worse as I was reading the mall signs as I worked my way around the city. Finally I was in the area where I was fairly familiar with but I was now down so low and the visibility was so poor that I didn't even want to try and get a special into Dayton since I felt they would question my judgment. At this point I am so close to home that I have to keep going. So, over the right side of I-70 I go at about, well let's say way too low. The closest airport in my path with a vor on the field was Richmond and at some point I would have to leave the safety of the highway and cut cross-country a little ways over to the airport.

To be continued...

## Velocity RG System History

Many of you have asked if you have the latest set up or not since you bought the airplane from someone else or whatever. Here's another history lesson....

### 1989-90

My father and I purchased a kit from Danny Maher and Velocity. We designed a retractable gear system for the aircraft and built it. Just before we flew the plane we had a fire that destroyed the plane. We went down and picked up another kit and built it in 5 months from scratch. We had no pre-molded bulkheads, no fast-builds, etc... we flew the plane down to Velocity to get approval from the factory on the system. Danny then started discounting the kits by \$500.00 and I would build the retract systems and sell them to Velocity owners. At this time, my father, myself, and a friend of ours bought a small airport just outside Dayton Ohio. I set up shop there to make the kits and to help people get their airplanes built and flying. Our airport had one 2,700 ft. long 36 ft. wide paved runway. That brings us to the first change in the system. We changed over to 6-ply tires on the mains since the 4-ply model supplied with the kit was not staying round. Before we moved to Florida in late 1992, we only made a couple of changes to nose gear system. The first nose gears had a tube weld at the top of the gear similar to the pivot tube that basically slid into slots in the original aluminum channel (non Elite) when the gear was down and locked. This was supposed to give lateral support as well as serve as a stop. It did fine as a stop but the gear still had side-to-side movement. At this point we added gussets to the pivot tube to strengthen that area. We also changed to a "captivator" so that the nose gear would go into a steel fork like device mounted to the forward face of the aluminum channel or canard bulkhead later. We then eliminated the top tube in the gear since it was not being used any more. We also went from an oil lite bushing in the aluminum channel to

*Continued on next page*

a steel bushing because of the wear involve with the oil lite. In the main gear, we went from a 3/8" main pivot bolt up to a 1/2" pivot bolt.

At this point, Danny wanted to sell his company and we were on his list. We ended up selling our interests in the airport and purchasing the assets of Velocity. Basically I purchased half and my father did the same. He came down here first as I was waiting for my second child to be born. That happened in December of 1992 and we moved down Jan. 1, 1993. After moving down to Florida, we dropped the Rockwell hardness from the range of 48-51 down to around 46. The reason for this was we would rather bend the leg than break it off. We also made a change in the torsional wrap lay-up schedule. Instead of using 8 layers total for wrapping, we added 4 more layers in the area of the gear that gets the most twist. So part of the gear had 12 layers of UNI. One of our customers got excited and broke a gear switch off forgetting that it had to be pulled out first. Because of this we changed the gear switch to a much heavier one. The next change in the gear system happen after a customer had a main linkage collapse. This was caused by a weak gas spring on the main gear over center linkage. Since the gas spring could fail at any time, we decided to make a change. At about the same time, one of our customers was a toy engineer and he came up with a lost motion lock arm arrangement. We incorporated those improvements so that the over-center linkage now had a tension spring mount on top of the linkage and it also had a lock arm that stretched across the front of the linkage and locked it. It was really neat and I can't take much credit for that. The linkage went through a couple of more changes in that the fork ends went from a one piece bent channel to individual legs that were welded to the main linkage tube. That change caused a problem initially so we ended up adding a gusset or a bridge between the fork legs to strengthen the bend areas. Later, after the XL came into existence, we went to 1/8" thick legs instead of the .090 ones we had in the past. We did not want to inventory both thick-

nesses of fork legs so we standardize to the thicker ones and made all linkages that way.

As you can see, most of the changes happened soon after we moved to Florida and took over the business. Obviously the linkage, the gear legs both main and nose, pivot bolt size, and the main hydraulic cylinder, changed slightly on the XL but the operation and design stayed the same. More recent, probably 4 years ago, we changed the fork casting to a much more robust unit. We had a few failures and tried different material but finally just changed the size of the casting and the upper radius. Originally this was done for the XLs because of the extra load on the casting but eventually we changed all four of the castings to the current style. The XL and the extra load and work being done by the gear system brought much of the current changes made about. It was best to make the changes to both models because we don't want to stock any more models than we have to. The reason I say this is that some of you with the standard RGs don't necessarily need to make all the changes that are in existence now. Also, about this time, we added cable guards to the pulley holders to eliminate the chance of the cable coming off. Two other changes on the XLRG that are not necessary on the small aircraft are the TACO gusset, which is a double gusset from the pivot tube to the gear, and the sandwich pivot bushing arrangement. The taco gusset explains itself but the sandwich pivot arrangement is basically a steel plate with a bushing welded or pressed into it. It has a knurled aluminum bushing on the outside of it to fill the hole. This plate / bushing slides in place and a matching plate slides on the bushing on the other side securing the bushing on both sides of the keel. The plates are then glued and bolted to the keel. This does two things, it takes away the variations in the gluing of the bushings only and it spreads the load into the keel. It also allows you to line everything up before you bolt the final side in place. One other change, which I was reluctant to make, was a change on the XL-5 to Carbon Fiber torsional wraps. We had been testing

a gear leg wrapped this way for quite a while and had not had any problems with it so we decided to make it part of the XL-5. We could have just wrapped it with some more Uni but we decided to go with the carbon. The original gear was designed for a 2,300 lb gross weight and now we are running them up close to 3,000 lbs. We initially made the change to S glass with the XL and now with the XL-5 have raised the bar further. Later we will discuss upgrades to the aircraft over the years.

#### **List of changes to the RG System:**

6- ply tires on the mains from the 4 ply that were on the original system  
Added gussets to the pivot tube of the nose gear.

Changed to a "captivator" to lock the nose gear down.

From an oil lite bushing in the aluminum channel to a steel bushing (old door style)

3/8" main pivot bolt up to a 1/2" pivot bolt in the std RG. (XL has always been 5/8".)

We dropped the Rockwell hardness from the range of 48-51 down to around 46.

Middle part of main gear torsional wrap went to 12 layers of UNI up from the original 8.

The over-center linkage was modified to a tension spring and a lost motion lock arm.

The fork end of the over-center linkage was changed from a channel to individual legs welded to the sides of the linkage.

Added a gusset between the two legs to strengthen them at the bends.

Later, after the XL came into existence, we went to 1/8" thick legs instead of the .090 ones we had in the past.

Standardized all linkages to the thicker fork ends.

We change the nose fork casting to a much more robust unit.

Added cable guards to the pulley holders.

We changed from a 1/8" single gusset to a double "taco" gusset at the nose gear pivot bushing and also changed to the sandwich pivot bushing arrangement in the keel.

The XL-5 went to Carbon Fiber torsional wraps.

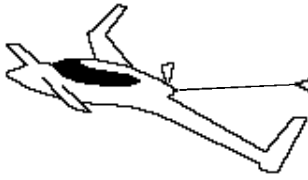

# FACTORY NEWS

by Duane Swing

## Total Electrical Failure

What is a total electrical failure? How does it happen? Can it be prevented? It has always been somewhat of a problem with me when I hear someone tell me he (or she) experienced a total electrical failure and from now on it will be two batteries and two alternators before they fly IFR again. Total electrical failure can only happen when you loose the output of the alternator and the battery has nothing left to provide those horses you need to run your electrical system. This can happen if the pilot doesn't notice that the alternator has given up the ghost and goes on flying until the battery is dead. Most alternators today have a low voltage output signal that can be wired to a warning light in the cockpit. Anytime the alternator quits, the light goes on and now you have the battery left to do the work. Most batteries we use will run everything you need on the Velocity for at least 4 to 5 hours and still have enough power to get the gear down and do all the needed communications. I have had only one "total" electrical failure in all my years of flying. This had nothing to do with the alternator (I had two of them) or the battery (The one I had was perfectly OK). The failure was of the master solenoid that connects the alternator/battery to the rest of the airplane electrical systems. Loosing the master solenoid in this case was the same as turning the master switch off. I happened to be flying IFR at night in a snowstorm when it happened. I am still around so it is obvious I survived the flight.

As most of you know, we put an alternator warning light in every Velocity we build. On our new dash 5, we actually have two separate warning lights, in addition to the volt/amp gauge. If I were going to

fly a lot of IFR, I would also put in a redundant master solenoid with two separate master switches so I could check each of them separately. For those of you out there that fly without a warning light on your alternator output, the day will come when you will loose your alternator and you will fly until the battery is dead. For many of you, this has already happened.

While I am talking about warning lights, it would not be a bad idea to install a low vacuum warning light also. Easy to do and could save your life in IFR conditions. Call Wayne and order the switch, it isn't expensive.

While I am talking about warning lights, why not go the extra step and put one on the output side of the starter solenoid. This will warn you if the solenoid "hangs up" and the starter keeps turning even after the starter switch is released and the engine is running. From first hand experience, once higher RPM is established, like at take-off, the

starter will "motorize" and cause high voltage to feed back into the battery and the battery will actually blow up. This is also a case of "total" electrical failure.

## Door Opening Problems

We have had a case where an XL pilot door was not latched and a take-off was initiated. We had thought that the new strut location with the door being pulled shut would keep it in place even if the pilot's distraction caused him to not latch the door. Knowing now that it is still possible to take-off with an unlatched door and have the door open in flight created a final "fix" that should be incorporated in ALL elite door Velocities. It will cost you about \$15 in parts and take a couple hours to complete. The key is a micro switch located on the throttle arm of the fuel servo so that it will activate when the throttle is pushed forward. (take-off) Wire the NO (normally open) spade of the micro switch to any 12 volt source in the engine compartment. You can use a 1 amp inline fuse for this. Locate the COM (common) right angle spade terminal and run a wire forward through your duct to the red wire of a high output Radio Shack buzzer. The one that is the loudest is the one that has a rotating front plate that

*Continued on next page*

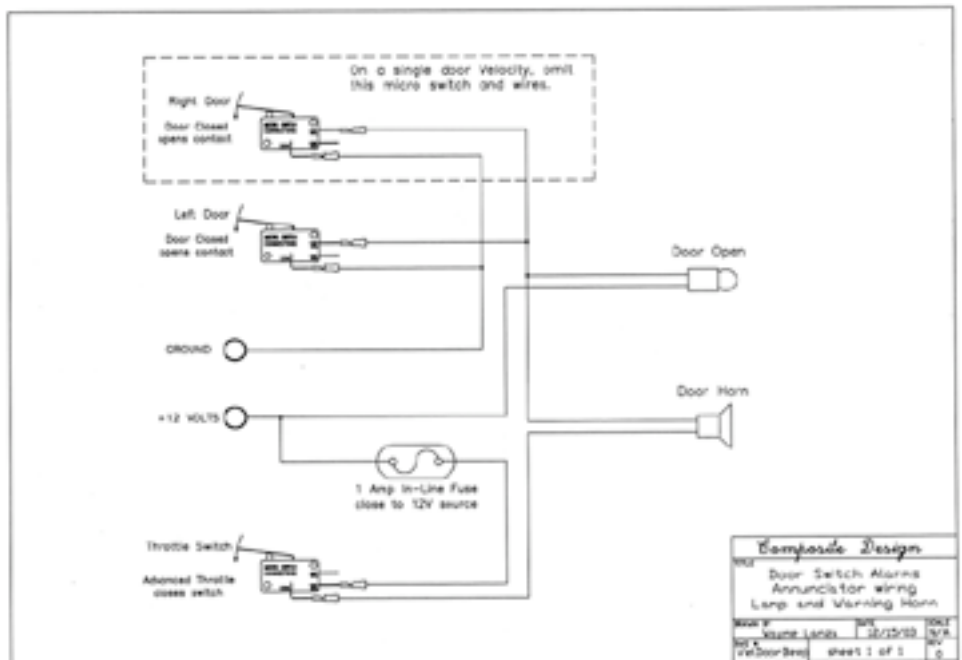



## Factory News

*Continued from previous page*

will shut off some of the sound if too loud. From the black wire side of the buzzer, run a wire to the ground wire that operates your door ajar light. You do have one of these don't you? This can either be at the light itself or at the door switch. Make sure you don't connect this wire to the + 12 volt side of the door light. It goes to the ground side. If wired correct, the horn will blow when the door ajar light is on and the throttle is advanced to full power position. The horn will not operate if the door ajar light is not on. (See wiring schematic on page 8.)

## Peter Garrison's and Aftermath

Melmoth I and Melmoth II are familiar names to those of us old enough to remember the struggles Peter Garrison went through designing and building I and then II. He is one of my favorite writers for *Flying Magazine* and wrote an interesting

article in the February issue called "Amateur Accidents." He analyzed experimental aircraft accidents for a one-month period and found some disturbing facts. All the accidents he reported on were just those that resulted in a death. Here is a condensed version of what he found:

- Challenger II, a two-seat ultralight, struck trees during an attempted return to the airport after an engine failure. Low time unlicensed pilot was unable to recover from a stall/spin.

- Mohawk I, also an ultralight that had previously been flown by an experienced pilot who reported the airplane unstable and should not be flown. Owner flew anyway and a stall/spin ended his life.

- BD 5 struck the ground at a high rate of speed apparently losing control after a high-speed pass.

- Right upper wing departed a biplane caused by a bolt coming loose. Examination found over half a dozen additional jam nuts not tightened and an improperly glued wooden doubler.

- A replica Curtiss Goshawk with a 280 horsepower radial engine stalled and spun soon after takeoff, killing the pilot. The surviving passenger reported that it had been noted prior to the flight that the ailerons did not have full travel and the strakes were hitting the flying wires causing a wing warp.

- A Giles G-202 competition aerobatic airplane stalled and spun while S-turning for final at Oshkosh. The pilot had over 22,000 hours with 35 hours in type.

- Kolb Sling Shot crashed while attempting an engine out landing due to fuel starvation caused by an improperly vented fuel tank. The airplane stalled and spun into the ground.

- A Glasair III stalled and spun while S-turning for spacing behind a slower aircraft on a landing approach. In this case, the family of the pilot sued the company who had performed maintenance on the airplane.

- A Barnett J4B gyroplane crashed due to a nose heavy condition caused by builder error.

- A Glastar crashed when the pilot lost control while flying at 13,000 feet. No cause could be found.

- The last for that month was a Lancair 360 that flew into a Level Three to a Level Five thunderstorm and killed both occupants.

Peter goes on to say that "what he finds striking is the high proportion of accidents that occur on first flights or inadvertent flights, or involve inexperienced or unlicensed pilots; the high proportion of stall-spin or loss-of-control accidents; and the comparatively high proportion of events involving gross mechanical problems such as structural or engine failure or marginal flying qualities."

It has often been reported that the accident rate of homebuilt airplanes is no greater than that of production airplanes. I hope this is correct. From our point of view, we never want any of you to be involved in an accident and we try to do what we can to prevent it from happening. It is important that you also make that

*Continued on next page*

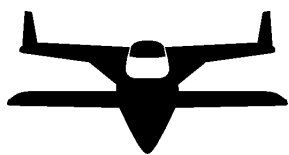

## April 15, 2004 Factory Open House Workshop Schedule

**Thursday, April 15, 2004** - Factory's quarterly open house in Sebastian Florida (X26). *Velocity will arrange ground transportation to and from Sun N Fun for \$10 per person, for those who want to take a field trip to the factory. Demo flights will be given throughout the day in the Velocity XL-RG model, at a special reduced price today of \$100. We recommend you make advance reservations by calling Melanie at 772-589-1860.*

10:00am	Factory Tour
Noon	Lunch, courtesy of Velocity... enjoy!
2:00pm	Program Ends

Please be sure to call the factory and RSVP! Friday arrivals can book a room at the Key West Inn at Captain Hiram's here in Sebastian. Call 800-833-0555 and mention Velocity to get a corporate rate. When you call the factory to RSVP, let us know when you plan on arriving so we can make arrangements for transportation, etc.

Check [velocityaircraft.com](http://velocityaircraft.com) for up-to-date details

## Factory News

*Continued from previous page*

extra effort to fly safe. A friend of mine had a placard on his instrument panel that read, "In God we trust, everything else we check."

## Proper Leaning Procedures

Old habits are hard to break. As some of you know, we spent a considerable amount of time getting the Firefly ready for a record pole to pole, around the world flight. (See article). One of the problems is the 4000+ mile leg over the South Pole and how to achieve the absolute best fuel economy. Gus McLeod is certainly a gutsy type guy who has spent a lot of time in the rear seat of a Stearman (North Pole twice in this open cockpit biplane) and his Twin Beach 18. Leaning the mixture in these carbureted beasts is not much of a science. The fuel injected 260 Lycoming is a totally different type animal. Gus is not the only skeptic around us that just flatly refuse to lean beyond 50 degrees on the rich side of peak. This is what he was taught early on and to change these old habits is not easy. To understand the dynamics of proper leaning, I encourage all of you to read an article published in the February issue of AOPA called "The College of Powerplant Knowledge." It would take too much of our Velocity Views to properly address all that this article has to say. The important thing for you to understand is that according to the experts who conduct this training school, leaning from 50 to 100 degrees on the rich side of peak is one of the more destructive things you can do to your engine. They show evidence that leaning to 50 degrees on the LEAN side of peak is by far less stress on your engine, will prolong engine life, reduce carbon deposits, reduce spark plug cleaning and more. Read this article and come to your own conclusions.

## And Now About the Firefly

One of the last "firsts" in the world of aviation, is a solo flight around the world from pole to pole. I remember reading about the attempts made

even back in the 60's and 70's, which always ended in either a wrecked airplane, not enough fuel to continue or giving up due to the horrible weather this type flight is guaranteed to enter. Max Conrad, one of the early distance record holders, left his Aztec in a snow bank in the Antarctic during one of his many attempts. Others had similar fates. Why then, does Gus McLeod think he has what it takes to complete this feat? First of all, he needed an airplane that could fly a minimum of 4000 miles non-stop. This would allow him to over fly the South Pole and backtrack to a spot where he could land without the 70 and 80 miles per hour winds that are usually present at the pole. After considering many different airplanes, he called to ask if we wanted to donate an airplane for such a mission and if it could be configured with enough fuel for such a trip. The only airplane we have here that could be used was the Firefly. After several calls to KARI (Korean Aerospace Research Institute), which actually owns the airplane, it was agreed that Gus could, indeed, use this airplane for the attempt. KARI also agreed to donate the airplane to an aviation museum once the record was confirmed. Now it was time to begin the work needed to transform this airplane into the flying fuel tank Gus would need.

Perhaps I should stop right here and say that neither Velocity, as a company, nor myself, can condone anyone who would want to put their life and limb in such a perilous position for the sake of doing something no one else has been able to do. Some of you will question the wisdom of Velocity even wanting to get involved in such a mission. We certainly dismiss any advertisement blitz that might come from such a feat due to the negative publicity that would ensue if anything terrible happened to Gus. Some will say that an accident would only raise the insurance premiums on all the Velocity aircraft if something happened. This, of course is not a problem because Gus is carrying no insurance at all. I used every

persuasive argument I could muster to try to convince Gus this was not a wise thing to do and for what gain? Certainly his financial position will not benefit, and, in fact, he is funding the entire trip out of his own pocket with the exception of some donated equipment. His only answer was that it was just something he had to try and for much the same reason that Max Conrad and others just would not give up in their desire to do something that the experts said was impossible. Most of you don't even know who Max Conrad is, or what records he set and still holds. Max died of old age with little to show for his aviation milestones.

Here are some of the things we did to prepare the Firefly for the trip: We stripped most of the interior out of the airplane including all the seats except the pilot's. Next we built additional fuel tanks into the fuselage to fill just about all the available space. The total fuel load when full is an amazing 347 gallons. With the empty weight of the airplane and a pilot weight of 275 lbs. we figured the airplane would have to lift off at a gross weight of slightly over 4,000 lbs. This is 2 1/2 times the empty weight. We also added a second com radio, a TruTrack autopilot, Blue Mountain EFIS Lite, a satellite based telephone system, a dual channel ELT and provisions for a heated suit Gus will be wearing when flying in the 30 below zero temperatures when over the poles. We also provided a way of shutting off some of the NACA cooling air going to the engine and a way of shutting off all the rear oil cooler air along with the majority of the front oil cooling air to keep the engine happy during the long cold weather flying. We had only three weeks to get the airplane ready so that Gus could get across the South Pole during the window open to him. The only time it is possible is December, January and the first two week of February. At other times it is just too hostile to attempt. As I write, Gus has had to reverse his course as the South Pole weather is just too wicked. On one try, he left

*Continued on next page*

## Factory News

*Continued from previous page*

Ushuaia Argentina and picked up a load of ice over the 1000 mile Drake Passage and had to land on a 2500 foot gravel strip in Antarctic. On another trip he lost power due to a load of water in his fuel and made an emergency landing on a dirt road. When all is done, he will have flown over 40,000 miles with over 10,000 of them over water. To see how he is doing, log on to his web site at [www.gusmcleod.com](http://www.gusmcleod.com). Click on to the Gus Pilot Log box and then click on the underlined Flight Explorer. This will show you his latest real time position anywhere in the world.

## What's Wrong With This Picture?

After all I have said about the need for a factory check-out, and even recurrency training in some cases, something like this pops up that absolutely blows my mind.

One of our Velocity owners called the man responsible for the completion of his XLRG and wanted to know if he would be willing to check him out in his newly built Velocity. The owner was told by the builder that he was not qualified to do this and that he should call the factory and schedule this check-out. The owner told the builder that he didn't have enough flight time to qualify for the insurance anyway and a factory checkout was just a waste of his time and money. He said he would just have to go it alone. I told the builder of the airplane that if I were in his shoes, I would not complete the airplane until he received adequate training. A low time pilot with no canard / Velocity experience will probably hurt himself and his airplane if he tries to teach himself in an airplane that has never flown before. The builder could be facing a liability issue if the owner was seriously hurt in an airplane that was built by someone else.

It is difficult for me to understand the owner's position. To jeopardize the amount of money he has already

spend to save a couple bucks on training just flatly makes no sense. One of his concerns about the factory training is that we require he have a complex endorsement. This requirement is so that his experience level will be a little higher than if he didn't have this qualification. We have certainly checked out many of our builders who did not possess this endorsement and we would have done so with this gentlemen if he would have just asked. Perhaps he is a subscriber to the Views and will change his mind and call Nathan for this needed training once he reads my warning.

As I have said before, the insurance companies review ALL aircraft accidents that happen within the United States and base their decisions on the number of airplanes that have been involved in an accident even if they are not the underwriter. This is called risk management by them and any Velocity accident will be reviewed and the availability and cost of our insurance is adjusted accordingly.

## Insurance Issues

Speaking of insurance, I just returned from speaking to an EAA chapter at Spruce Creek in the Daytona Beach area and was sur-

prised by the number of experimental airplane owners that could not get insurance. I spoke to one gentleman who has every rating in the book and he cannot find insurance on his SX300. This is a high performance all-metal, two seat 300-horse airplane. He said they stopped writing insurance a couple years ago when too many low time pilots were having accidents and no way to get a proper check-out. I spoke to a fellow with a Lancair IV and he said he could just not justify the \$18,000 per year demanded by the insurance company and elected to go without insurance. Another former airline pilot owned a Russian L 39 jet trainer and although he said the airplane was not difficult to fly, insurance was just not possible. It is licensed in the experimental, exhibition category. People who live at the Spruce Creek fly-in community are not your average income pilot. Most live in multi-million dollar homes and fly everything from small Pitts specials to 10 passenger jets. Some own two and three airplanes. These are people who would not drive a car around the block without insurance and yet are left without any protection in their experimental airplanes.

Perhaps we don't have it so bad after all.

### Flight Check! Be Safe!

Velocity Service Center Inc. offers flight training for builders/pilots to safely learn how to transition into flying a Velocity. Get a **Flight Check Out** prior to your first flight!

Flight training is available from:

- Nathan Rigaud, CFII
- Brendan O'Riordan, Flight Advisor
- Scott Baker, CFII

The following Flight Instructors have also been approved by Avemco Insurance:

- Sam DaSilva - Seminole FL 727-595-6384
- Mike Gunvordahl - Burke SD 605-775-2952
- Mack Murphree - Dayton NV 775-246-9364
- Manny Lewis - Scotia NY 518-399-8614

Don't take a chance, get checked out prior to your first flight. Please note that you should be current in some other type of aircraft prior to your Velocity check out. The purpose of the "flight check" program is to transition you from flying other aircraft types (like a Cessna) to a canard pusher (Velocity).



# Safety Corner

Accident & Incident Reports,  
Maintenance & Service Difficulties

## IO550 Continental

We recently found out that the bolts that hold the engine to the engine mount on the Continental IO550 are slightly too long. This does not allow the spacer between the rubber mounts to tighten up. In any case, don't panic. When you get a chance, pull one of the bolts and verify that the threads have bottomed out. You will be able to see this since the edge of the treaded section should be shiny like it was trying to be threaded by the threads in the engine. If it is, call Natalie and get the shorter bolts sent to you. The reason you can't just add a washer is that we use that special lock washer under the head of the bolt that doesn't allow any additional washers. You could add a washer between the engine and the mount as well. This does two things; it raises the engine and gives you more gap between the engine mount and the oil cooler. If you are flying, check your engine mount to see if the oil cooler has been rubbing the mount. It would be a good idea to put a bead of silicone between the two. If you are not going to do that, get the other bolts and keep the ones you have in case you decide to do that at another time.

Also, if you have not plumbed your fuel system, it would be best to make the switch to 1/2" lines. Natalie knows all about it so you can call here to arrange it. Several are flying with the 3/8" lines and no problems but 1/2" would be best.

## Hydraulic Gear Pump

Since I haven't mentioned this in a while, I thought I would inform again. There are two things that control the amount of pressure the system operates at. One is the obvious pressure switch that turns the pump off and on when it reaches a certain

pressures. The other is the pressure relief setting inside the pump. These relief valves dump pressure if it goes above a specified level. These relief pressures need to be higher than the pressure switch limits in order for the pressure switch to do its thing. If you try to adjust your pressure switch up and the pump then continues to run, it is because the pump is dumping pressure. You will have to go into the pump, involves removing the reservoir, and adjust the relief pressures. If you need to do this, just call for details.

## New Rudder Pedal/Brake System

We decided to go with a stronger spring on the hydraulic cylinders and this spring is slightly larger in diameter than the old ones. Because of this we found it best if we added an AN 970 -3 (3/16 wide area washer) drilled out to 5/16, to the top of the spring, to keep the spring from riding up on the lock nut.

## Nose Gear Castings

Years ago we made a change to the nose gear castings and told everyone that we would update theirs for a limited time for \$50. Normally we sell the machined castings for a lot more. We assumed that all were informed but just in case you were you are informed again. The reason we made the change involved some failures of the castings. Whether they involved bad landings or shimmys was not that important to us since we had more than one failure and this should not happen. We found excessive porosity in the castings and initially went to a different material. The result was a beautiful casting with no porosity but was so brittle we rejected it. Instead of different material, we increased the thickness of the fork and also the upper radius. We load tested this new fork and

found it to be about twice as strong as the old one. It is easy to tell the difference between the old and new since on the outer surface of the fork at the axle location there used to be an extended boss to allow for more threads and the new one does not. We just kept that extra boss thickness on up the fork. This problem first showed up on the big fork (fork for a 5.00 X 5) since we had extended the legs of the fork for the bigger tire. The smaller fork (for the slick tire) although has broken, was not as much of a concern. We have stressed to the manufacture that they need to do their best to minimize porosity in those castings. To my knowledge we have not had any problems with the new castings.

## Wing Fences

We have heard a lot about wing fences and the effects they have on the flying qualities. We should have our feedback on this in the next newsletter. We should start testing different combinations to see if they warrant installation. In case you haven't heard, these fences go on the trailing edge of the wing to straighten out the span wise flow and in doing so, enhances the performance of the wing.

## Tire Pressures

We know how important it is in your car but it is even more important for your aircraft to keep your tires inflated to their proper pressure. It is also important to check your toe in once in a while especially for the fixed gear aircraft, as it seems to change more on those.

## Exhaust Systems

We have made a change in the exhaust system for the Lycoming IO540s to the same style as the Continental IO550. This system has three separate pipes coming together and going straight down out of the cowl. The other system is just fine it is just a little easier to make new style. We just thought we would let you know before you start seeing them and wondering why.

*Continued on next page*

## Safety Corner

*Continued from previous page*

### Propeller Repair on the MT

I have made several repairs on the MT propellers since we have been using them. I have repaired the blades after someone lifted the plane and blades hit the ground, to just screw and rock damage. It is not difficult but it should be done correctly. A nick in the propeller just calls for a little sanding, filling, sanding, and painting. When the tips are broken, it calls for more attention to detail. Since it would take to long to describe here, I will try and right up a small manual for this. Until then, let me know if you damage your prop and I will help you figure out the repair.

### 3003 Aluminum Tubing

We have talked about proper flaring of aluminum tubing and the importance of preparing the tubing before the flaring process, but what happens after that? We have found some problems here dealing with over tightening of the aluminum lines. When tightening the oil or fuel lines, make sure you do not over tighten them. If, when tightening the lines, it feels like it doesn't take any more pressure but you are able to continue turning the fitting, you are going too far and squeezing the aluminum between the sleeve and fitting. If you want to, you can do your own experiment to see what happens to flair when it is smashed. Make a sample up and lock the fitting into a vise. Then tighten the fitting beyond what you think it should take, loosen the fitting, and then tighten again. When you are done, inspect the damage.

**Please check your mailing label on the last page to see when your NEWSLETTER subscription expires...**

"Paid Thru Vol xx" indicates the last issue you are paid through. Also, You can pre-pay for as many future years as you'd like. Please renew today! See the last page for details.

## CFI Notams

*by Nathan Rigaud, CFII*



### Pre-Flight of Your Velocity:

Let's talk about the pre-flight. With the old saying "it flew in", the pre-flight is sometimes left out. The Velocity does not have many parts to look over, since most of the flight controls are hidden. Let's take you around a normal preflight.

Before you move the airplane, take a look on the ground for any fluids. Brake fluid, hydraulic fluid, fuel and oil. Once you move the airplane, you may have a hard time finding out where the fluid is coming from.

First, let's start with the cabin area. I like to open the doors and check them for proper operation, never know when a door pin may come loose and keep the door from opening. Be sure all electrical and mags are in the off position. Check the fuel sight gauges for enough fuel for your flight. I like to also look under the instrument panel to be sure the canard bolts and nuts are in place. I also look in the center to check for my elevator bolt and nut. Check the flight controls by moving the control stick full direction and move the rudder pedals for travel.

Moving on to the nose, I check inside the nose compartment from under the airplane inside the gear doors. I look for any obstruction that may not allow the nose wheel to come down and lock. Look over the gear leg itself, on some of the older models, we have had cracks show up in the gusset area by the pivot bolt. Lift the nose and check the nose wheel tension; if not tight enough, it will shimmy and lead to a gusset crack that I talked about earlier. Check the oil cooler in the nose for any obstruction, this will lead to a high oil tem-

perature and you will have to land. Check all static ports and pitot tube and remove all covers. These should be located on the pilot side under the canard. Look over the canard, be sure to check all the hinges for proper attachment and screws and nuts. Check the balance weights at the outboard for attachment and clearance into the canard. Move the elevator up and down to be sure you are getting the proper throw and that you see the control stick moving. Do this for pilot and co-pilot sides of the canard and elevators. If you do not have fuel sight gauges, open the fuel cap, and use a stick to check fuel level. Do not trust your electronic fuel gauges. Check the fuel caps for proper installation and locked. If put on wrong, they will allow the fuel cap to leak and have improper fuel drain into the sump. Looking over the wings, you can move the wings up and down to listen for any loose bolts that hold the wing on. Move the rudders out and be sure they come back on their own with no help. The ailerons should be moved up and down, and, at the same time, look for opposite throw on the other side and check to be sure the control stick is moving the proper direction. Check to be sure all hinge pins are in place; if not set up correct, these pins will move out of the hinge. This should be done for both wings. Let's check the main landing gear. I look for proper tire inflation, brake pads, and gear door attachment. Look for general condition of the gear itself, you may have had a hard landing and put a few cracks in the gear. Propeller check – this one is very important – check all blades for nicks, cracks, and check the tips to be sure you did not get the nose too high on take off or landing. One thing with a pusher, anything that comes off of the airplane will go through the prop. This includes doors, gear doors, screws, and any "remove before flight covers" left on. Screws seem to be the biggest problem with any pusher; they come from inside the cowl and outside panels. If you see a screw loose, it is best to take it out and check the nut plate. Check the fuel sumps for water and dirt, and check your oil level for your engine. Do not take anything for granted, even if you just flew in and only stayed for an hour; take that extra time to check things over.

# Event & Production News

by Scott Baker



*Chad Holland applies carbon bid torsional wrap to XL-5 retract gear leg.*

I'm singing the low tech – high tech blues.

Velocity, as you all know, is a parts supplier for a good looking, great performing, and fun to fly kit-built aircraft. Dan Maher founded the company on the premise that the Velocity kit be designed for the first-time builder – and as such, incorporated a lot of simple “low tech” products and procedures to make it easy (and less costly) to build this incredible aircraft.

Few kit-built, fiberglass based, aircraft companies existed in 1984 when Velocity began supporting the experimental home-built aircraft market. Back then most experimental aircraft were produced from plans. This caused many to look at Velocity's manufacturing methods, which used molds and vacuum bagging, as “high tech”. Today there are composite aircraft manufacturers that use precisely controlled processes that feature pre-impregnated (resin and hardener) fiberglass materials that require large freezers for storage and autoclaves for heating and molding the parts into their finished state. Automatic cutting machines quickly cut fiberglass cloth for smaller parts and minimize waste. It is common to see a combination of carbon fiber, S-glass, Kevlar, and other “exotic” fibers being used in aircraft designs. When measured against these standards, Velocity is remarkably “low tech” by comparison.



*Lambert Kneifel attaches vacuum bag umbilical line to XL fuselage mold part.*



*Charlie McElyea fabricates XL-5 drop-down keel cover using carbon fibre BID.*

This is not to say that the Velocity design is inferior to products produced by “high tech” companies. When Dan Maher started Velocity, he surrounded himself with some pretty knowledgeable and talented people. A lot of technical research, professional design study, and flight-testing was done to arrive at the first Velocity aircraft. The result of this work is a structurally strong, aerodynamically efficient, stable, spin-resistant, and fun-to-fly aircraft that keeps up (or better) the best of the competition – but at a fraction of the price.

Now ... I know this to be true, and you know this true – but some of the people who visit Velocity and who are evaluating experimental aviation

*Continued on the next page*

## Production News

*Continued from previous page*

for the first time are expecting something a little more “high tech”. I can see it in their eyes ...”I wonder where the computer drawing department is located? Where’s the Structural Engineer’s office? Why aren’t aircraft blueprints and drawings hanging on the walls?” It’s sometimes hard to overcome first-hand expectations – which is why I’m singing the “blues”.

A branch of the government is entertaining the idea of purchasing a Velocity to support their flying research missions, but before they do so they would like to review the structural data that supports the fact that the Velocity really can fly. It’s not an unreasonable request – however the problem for us is that there isn’t a comprehensive set of published data that states exactly that – another reason why I’m singing the “blues”.

It’s inevitable that Velocity, Inc. will need to bolster some of its manufacturing processes and a lot of the background documentation to address the “high tech” expectations of today’s buyers. I must admit however, that there is a part of me that smiles at the “high tech” person who is agonizing over engineering data and putting off their decision to build a Velocity as I fly overhead in this truly remarkable aircraft.

I can see the “blue’s” lifting now. Call me - “Low tech and proud of it”.



*Jim Parrot covers wings with triax cloth as part of the Fastbuild Wings Option process.*

## Maintenance Notes

*by Michael J. Snyder  
Private Pilot, A&P, IA*



To start this article off, I would like to begin by recommending that each builder obtain a copy of AC 43.13-1B & AC 43.13-2B, titled, ACCEPTABLE METHODS, TECHNIQUES, AND PRACTICES - AIRCRAFT INSPECTION AND REPAIR. This book contains methods of maintaining all types of aircraft.

But what is common to all such as proper use of aircraft hardware, I see airplanes come through here where people have substituted items with similar hardware and not realizing that they are doing it incorrectly.

The manual describes using the correct grip length & thread engagement. Another chapter on hydraulic lines, hoses, and flitting demonstrates proper routing, bend radii and clamping procedures, electrical systems and wire. They explain correct bonding, grounding, routing and wire gauge selection. In addition, a great chapter on weight & balance which takes you through the basics to computing your own empty weight W&B and running computations on Forward & Aft limits. I think most of you would like to page through the manual just for the general information.

Another excellent reference book is *Firewall Forward* by Tony Bingels. It covers engine selection, firewall prep; exhaust systems, Mounts, Plumbing and electrical systems. I think this is an excellent source of information for the first time builder and seasoned veteran.

Another point I would like to touch on is many builders make alterations and deviate from the plans to reinvent the wheel, not realizing that this change could affect other systems installations. So, think things thoroughly and plan your installations carefully.

Take care and hope to talk to you soon!

....

## Velocity Sun ‘N Fun BBQ Picnic Dinner Friday, April 16

Back by popular demand, the Velocity Sun ‘N Fun BBQ Picnic Dinner will be hosted in Activity Tent #2 at Sun ‘N Fun. Social hour begins at 5:00pm, with a beer/wine/soft drink bar. A catered BBQ dinner buffet, by the nationally renowned Rib Crib restaurant will follow, with ample portions of BBQ chicken breast and BBQ chopped brisket, cole slaw, potato salad, baked beans and bread. And save room for dessert! Tickets are \$15 for adults and children over 3 (free for under age 3). We are limited to the first 125 people, so please RSVP with Melanie or Rhonda at (772) 589-1860. See you there!

# Builders Forum

Builders Forum is full of tips, information and letters ("material") supplied to *Velocity Views* Newsletter from individuals that are Velocity builders (or want to be builders). It is provided as "USE AT YOUR OWN RISK" material. Neither Velocity Inc. (The Velocity Factory) nor *Velocity Views* Newsletter (Lavoie Graphics & Rick Lavoie) have endorsed this material, and disclaim any liability for the use of this material. Individuals who use this material for the operation, maintenance, or construction of their homebuilt aircraft do so at their own discretion and at their own risk. Any variance from the builders manual is high risk.

## Finding our Velocity

*From Dave Dent, Livermore CA*

My story is a little different. We found this Velocity XL/RG for sale on the web and it didn't seem right, but, as it turns out, it was. Sometimes you think you're seeing things but this time it was right. The Velocity was in Australia and I know that seems far to go and look at a plane when you live in the U.S. but it may be just what you want.

My partner Gene and I had been looking for a Velocity for better than eight months when we found this one. I had looked at a number of Velocity's, some real nice and some not so nice. We really wanted a XL but they are hard to find and most are so expensive and out of our reach, we didn't even go to look at them. One of the planes we flew down and looked at was in the middle of nowhere in New Mexico. It was a very low time Standard with Elite doors on it. It had been stored in a hangar for over three years and not been flown since the engine had been gone through, because of a prop strike and a gear collapse. The fellow was just not up to flying it after the accident and just wanted to get out of it. After flying there and arriving late in the afternoon we only had about one hour to spend looking at it. It was an OK plane but not what we wanted. We needed more room and of course more power. After sitting in it and finding no more room than in the Cozy and that bulkhead in the way behind the front seat, we knew then our plane had to be a XL. So from then on it was a XL or none at all. We had looked at another XL in Fresno but the fellow had a buyer already to come out and buy it. He was asking a fair price for it and now I know he was asking a great price for it. For since then these XL's have gone up well over \$100,000 US in the last year. And I can see why. I do believe



they are a much more comfortable plane than a LanceAir and a lot more efficient as far as fuel and comfort go. The XL is a real four place aircraft, without hitting the gross load and range for the speed. I myself have been flying canard aircraft since 1985 and my partner has for the last year and a half. Flying Long EZ's, Cozy's and alike. I have 1400 hrs in my Long EZ alone. So both of us were looking for the Velocity, our dream plane. I have had a picture of one on my hangar bulletin board for better than five years now. But it was just out of reach. Because I was building another plane and getting it past my wife

were some real walls that had to be climbed before even thinking on how I would find one. Then Gene came through and he asked me to check out this Cozy IV he wanted to buy. That's when it all started. He bought the Cozy IV and I rebuilt it to show type plane and then we both decided to go after a Velocity buy selling our two planes. They are both for sale now, seeing that we have a beautiful XL on a boat coming our way from down-under.

When we saw the add for the XL we made some email exchanges and we were on a roll. The fellow selling it in Australia said he had come down

*Continued on the next page*



## BuildersForum

*Continued from previous page*

with diabetes 2 and couldn't fly it anymore. So to him it served no purpose. It was completed in 1999 and had been flown only 52 hours. But he had another fellow there wanting to buy it but if there were any complications in the ways and means of the purchase we would have first choice of refusal. Within a week we were back in the mix. So we bought a ticket and I headed for Sydney. I have never been treated so well on arrival in a foreign land. Leon was waiting as I came out of customs and we had exchanged pictures via email so we would know each other at the airport. This worked great. We headed right for the airport where he kept the plane. You know how that is. The planes come first on such a mission. No stopping or finding rooms, unpacking, eating or anything like that. Just get me to the plane. Everything else will come later. The first problem I had then was getting use to driving on the left hand side of the road. Boy I hadn't done this since being in Ireland two years ago. It is a sense of vertigo that takes a couple of days to get use to.

All the way to the airport about 30 minutes away was full of questions. I had a pretty good idea what it was going to be like because of the pictures that Leon, the owner, had mailed to me. But as you know, pictures don't always tell the truth. Well as we come up to this little airport that could have been any small GA airport in the states, we pulled up to a large hangar that later I found out belonged to the fellow that did most of the building of the plane. There it was sitting just like the pictures he had sent. It was just as beautiful as I thought it would be. I didn't want to seem too excited because we hadn't finished talking money yet. So I tried to look unenthusiastic as we approached the plane. I know he was looking close to see if I was. Boy it was hard. So as he was opening the hangar doors I started going over the plane. I kept saying to myself, "this is what I want" over and over again.

The plane, built in 1999, seemed like it was finished the month before. Having been built in Australia there are a few things different but nothing



that would keep it from flying anywhere in the states. Boy I wanted to fly it bad. But having just flown better than 16 hours getting there I was in no shape. Leon couldn't fly it anyway and the fellow that was going to fly with me didn't come in that day because he was working at Qantas Air. It was a very nice day and it would have been great. But I could wait. So then after spending a good two or three hours, I asked what hotel I was going to stay at while there. He said "my hotel" so we started for his place. Come to find out it was another 30 minutes away in New South Wales. Prior to going to his home we stopped off at his factory to meet his lovely wife and son. His company builds printers that go into things like slot machines or poker machines, as they call them. Also in to things like self serve gas pumps and auto receipt machines. A very large business he and his wife started over twenty years ago. We then went on to his home. A very large home on the outskirts of Camden a small community that isn't affected by tourists.

The next morning Leon and I went into the quiet little town and had breakfast and headed to the airport. Camden airport is just a stone's throw from Leon's house but the builder and fellow that maintains the plane is at the other airport so we drove the thirty minutes back there. It didn't turn

out to be too good of a day to fly the plane. Solid overcast and typical spring day with chance of rain all day. So we stayed in and I took the day looking over the plane and records, etc. The next day proved to be just the opposite. So by 11:00 we were off and flying. I felt like a bird shoved out of the nest, with a new set of wings. The plane was wonderful to fly. And performed just like I thought it would. I had flown the Cozy IV from the right seat a number of times so I had no problem flying the Velocity from the right side. Boy does that plane perform. We were climbing out at 1200fmp and seeing 170Ks on the airspeed. I found the ailerons a little sluggish but that's all. Richard, the fellow that did most of the building, said there was a fix for that and he was going to get me the information on it.

Richard starting laughing about five minutes after I took control of the plane. I asked what was so funny. He said "by the looks of things this is going to be my last flight in this bird". I then said "You are very much so right. Let's take it back and start taking it apart and ship it to the US." After another twenty minutes or so, we made an uneventful landing and taxied back to the hangar. Leon knew for sure then that I wanted the plane.

*Continued on the next page*

---

# A&P Talk

by Brendan O'Riordan, CFII, A&P



## Fuel System Alternatives

While building several airplanes in the Velocity Service Center we have come up with some changes to the standard fuel system as described in the manual. I wanted to pass these ideas along to builders who are still constructing their airplanes as an alternative.

First off we have started using a different fuel tank screen in the main tanks. The book describes bonding in a 3/8" aluminum tube into the tanks and then using a Jeffco and Flox mix bonding in a screen over it so large

debris cannot clog the fuel line if it gets into the tank. Aircraft Spruce sells fuel finger strainers part number 05-17700. These strainers have a 3/8 pipe outside thread and a 1/4 pipe inside thread. To install these fuel strainers we first recess our strake at the point where the strainer will be installed. We do this by removing the inside glass and foam (beveling the foam at the edges to provide a smooth transition for glass.) The recess needs to be long enough and wide enough to allow the strainer to fit in it and not have any restrictions on any side. Sand the area around the recess you just made and cover with 2 bid. Next you can locate the hole in the side of your fuselage for your strainer. You want the strainer to go down in the recess lower than the rest of the strake but not touching the bottom of your recess. You can use a 1/2" drill to make the hole. Now you will need to install a hard point out of 1/4" aluminum that is tapped for 3/8 pipe to accept the strainer. Tap the aluminum and scuff it up on all sides and prep it for installation. Sand the inside of the fuselage where it will go as well. You can install your strainer in the hard point and place it in the hole you drilled it the side of the fuselage to locate where the

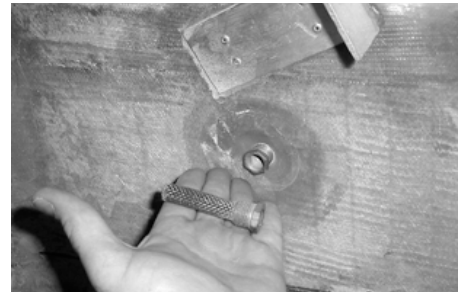

strainer needs to go. Once you have marked around the hard point with a pencil, install the hard point with EZ-poxy and Flox or Micro balloon. Glass over the hard point with 2 bid. Make sure that the area where the hole passes through the fuselage gets sealed properly. You may want to dig out a little of the foam and fill this with Epoxy and Micro by itself and go back and redrill it. Make sure to seal this area with Jeffco when sealing your tanks as well.

On some of our installation builders have wanted to use fuel selectors instead of the standard sump tank system described in the plans. While this allows you to select witch tank to use and manage the fuel so you will not have a fuel imbalance in your tanks it also adds complexity to the fuel system and to the pilot workload. We have a fuel selector installed on our XL-5 Demonstrator with a Continental IO-550 Fadec engine. The fuel selector originally was plumbed with 3/8" lines as we use in the standard sump installation. We were experiencing fuel pressure fluctuations at certain flight attitudes with different fuel loads. After some testing with equipment supplied by Continental we decided to increase the fuel line size to 1/2" and resolved the fuel pressure issues. If you are running the standard sump tank you may opt to increase to a 1/2" system but we have found that it is not necessary. Due to about 20 feet additional fuel line needed with a selector valve installation the increase to 1/2" fuel line is recommended to keep the drag in the fuel system as low as possible.

Many of our builders have told us that they don't like the sight tubes because they are worried about a back seat passenger accidentally breaking one. Some of our builders have come up with neat enclosures that protect the sight tube and allow

---

## BuildersForum

*Continued from previous page*

So I called my partner Gene and told him to get the money ready because I was shipping home our new Velocity. The plane was to arrive on the 26th of December, in Portland OR.

As soon as we were back in the hangar the tear down work started. The deal was closed and Leon arranged all the shipping. Because of the overhang on the main spar, the plane had to be put into an open sided transportainer. It's called a shipping plate. It's like an open shipping container with the sides and roof missing but the end plates fold up. It had to be shipped on a special ship that handles odd shape loads. Out of Australia it is called the Captain Maslov under a Russian flag.



I spent the next two days rapping the wings and canard in bubble wrap and taping. One of those days it reached 110 degrees in the hangar. Remember it's turning spring down there. Believe me I had very little sleep flying home because of the excitement. Now the big thing is to sell the two planes we have to make room in the hangar for our new Velocity. It was a very Merry Christmas for two fellows out here on the West Coast that love flying these wonder canard aircraft.

••••

*Continued on the next page*

## A&P Talk

Continued from previous page



a place to hide an LED light to view the sight tube at night. This is an inexpensive good-looking solution. A false bulkhead is made that starts right in the corner of the baggage area and comes out on an angle to pass in front of the sight tube. Another small piece is installed to run to the back of the strake. An opening is cut in the location of the sight tube and a piece of clear plexi-glass is installed in it. The panel in the picture isn't finished yet. The owner is having an overlay made that has the fuel quantity markings on it.

The last two pictures are to show you what we do at the service center when we get an airplane in that wasn't started properly. This is Frank Were and Dan and Mary Anne Smalley cutting off their strakes to start over again. They purchased this airplane partially built. Sometimes it is just quicker to start over.



## Buy Sell or Trade

Velocity parts, tools, kits, flying Velocity's: **Free** and exclusive to Velocity Views Subscribers.

**Place your ad here... FREE to all current subscribers. Individuals selling parts, tools, kits, & flying Velocity's. Your ad will run once per submission. See last page for deadlines. Please do not type text in all caps!**

### For Sale: Standard Velocity RG



Spoiled, pampered and hangared since birth! 565 hours on Hobbs - all "tweaked out" with no problems. Interior, engine, avionics, and airframe are all "10's". IFR certified, new PZL Franklin engine with IVO Inflight electric adjustable pitch prop, HSI, Strikefinder, S-tech auto pilot, PS engineering stereo audio panel, Stereo CD player/radio, Terra radios (2 com, 1 nav, 1 transponder), GPS moving map, JPI engine instrument plus EDM 700 engine monitor, and more. Built for traveling in style and comfort!

Sales Price is US \$115,000.

For complete details and lots of photos:  
[www.lavoiegraphics.com/velocityrg](http://www.lavoiegraphics.com/velocityrg)  
e-mail: RickL@lavoiegraphics.com  
Rick Lavoie 904-461-6912

**For Sale:** Standard Velocity can be made an Elite. Some work done on canard, elevators, winglets. Have antennas, experimental O360 Lycoming engine and starter and micro systems engine instruments, MT prop and extension; Century Autopilot and DG and some flight instruments; carriage for kit building. All are located in Sebastian, 3 miles from Velocity factory. Call Dave Huber (772)589-6737 or email: Jjanehuber@aol.com.

### For Sale: 173 LW Velocity FG

TT A&E 48 hours, MT constant speed electric prop (3 blade), One Collins Nav-com, transponder, apollo GPS. Standard panel and engine gauges. Engine is a IO-360 Lycoming, new barrels and all accessories have been overhauled and certified. Also all gyros have been certified. Also panel mounted intercom installed. Aircraft flies great and averages 172 mph cruise at 10,000 ft. Built by an A&P and certified hardware used thru-out. Aircraft at Medford OR in Medford Air's hangar. Delivery available. All factory updates are c/w and fresh condition report will be done at time of sale. Price \$89,000. Reason for selling - Lost medical.

## Factory Information



**Velocity Inc.**  
**Factory & Home Office:**

200 W Airport Rd  
Sebastian FL 32958 USA  
Ph: 772-589-1860  
Builders Hot Line: 772-589-0309  
Fax: 772-589-1893

### Builders HOT LINE

Please remember that on weekends and after hours, we do not answer the 772-589-1860 phone number. Our unlisted builders hot line is 772-589-0309 and, if we are here, this is the only number we will answer.

### Internet web site:

<http://velocityaircraft.com>

### e-mail addresses:

DuaneS@velocityaircraft.com  
ScottS@velocityaircraft.com  
BonnieS@velocityaircraft.com  
ScottB@velocityaircraft.com  
BrendanO@velocityaircraft.com

### Builder assistance:

[support@velocityaircraft.com](mailto:support@velocityaircraft.com)

### Other e-mail addresses:

[kitsales@velocityaircraft.com](mailto:kitsales@velocityaircraft.com)  
[accounting@velocityaircraft.com](mailto:accounting@velocityaircraft.com)  
[parts@velocityaircraft.com](mailto:parts@velocityaircraft.com)

### Velocity Service Center Inc.:

[flighttraining@velocityaircraft.com](mailto:flighttraining@velocityaircraft.com)  
[demos@velocityaircraft.com](mailto:demos@velocityaircraft.com)  
[maintenance@velocityaircraft.com](mailto:maintenance@velocityaircraft.com)

### Delivery Dates

<b>Quarter:</b>	<b>Mailed by:</b>
1st	January 15th
2nd	April 15th
3rd	July 15th
4th	October 15th

### Submission Deadlines

<b>Quarter:</b>	<b>Mail Date:</b>
1st	December 1st
2nd	March 1st
3rd	June 1st
4th	September 1st

Listed below are **options** for submitting your text. Do not type your text in all caps. Please send us **photos** and drawings too!

1) Send it on a 3-1/2" disk, a CD, or a Zip 100. This saves us from re-typing all that text. Don't format your text, just give us raw text, with no underlining, bold, or any other type of formats.

2) **E-Mail** your text file to me: richard@lavoiegraphics.com and please don't type in all caps.

3) If you don't have access to a computer, then we can scan in your **typed** page.

Note: If you need your photos & materials returned, please include a self addressed envelope.

*Velocity Views*  
is published **Quarterly** by:  
**Lavoie Graphics**  
26 Marshview Dr  
St. Augustine, FL 32080-5873  
Rick Lavoie, Editor  
Richard@lavoiegraphics.com

*Velocity Views* newsletter is published by Rick Lavoie / Lavoie Graphics as an agent for Velocity Inc. (the factory). Prior to printing, the factory reviews each volume published for accuracy.

*Velocity Views* newsletter material has been supplied voluntarily from the Velocity Factory, Builders, & Vendors. This material is printed for informational purposes only. Opinions expressed are those of the author. Lavoie Graphics & Rick Lavoie do not endorse and are not liable for the contents of such material. Use of this material is at your own risk. Any variance from the factory plans is a high risk endeavor. Any contemplated modifications should be reviewed and approved by Velocity Inc.

*Velocity Views* is a Trademark of Lavoie Graphics  
**Copyright** © 1994 - 2004 Lavoie Graphics All Rights Reserved.

No part may be reproduced or translated, stored in a database or retrieval system, or transmitted in any form by electronic, mechanical, photocopying, recording, or other means, except as expressly permitted by the publisher.

## Subscriptions

- **2004 Calendar Year Subscription** (Volumes 37-40): The annual cost is \$45.00 for mailing addresses within the United States. For all other mailing addresses, the cost is \$50.00 in US funds (covers Air Mail & special handling).

All subscriptions are sold on a calendar year basis. New subscribers joining mid year will be provided with back issues for that calendar year.

- **Back Issues** 1995 thru 2003 are available for sale at \$35.00 per calendar year in US funds.

Specify the year(s) you want when ordering back issues.

- You can also renew online at **lavoiegraphics.com** and pay with PayPal, Master Card, or Visa

- fax: 904-461-3146

- **Renewal Discount**

\$35.00 for renewals only if you mail a check to Rick Lavoie **by Dec 15th** and **pay by check** in US funds. Otherwise, you will be charged at the normal subscription rates of \$45 or \$50 (see above). Also, you can pre-pay as many future years as you choose at the \$35 rate.



FIRST CLASS

Rick Lavoie, Newsletter Editor  
26 Marshview Dr  
St. Augustine FL USA 32080-5873

FORWARD & ADDRESS SERVICE REQUESTED